

TS-90D MULTI-PURPOSE ABRASIVE BELT GRINDER

SHARPENS CUTTING DIES

BULLETIN TS-90D
REV. Dec. 2014



MULTI-PURPOSE

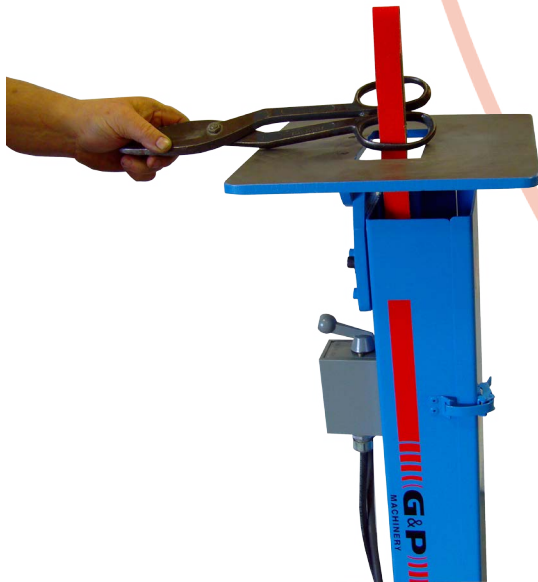

HARD TO REACH AREAS

For Grinding - Deburring - Sanding
1 H.P. Totally Enclosed Motor - 2750 SFPM Belt Speed

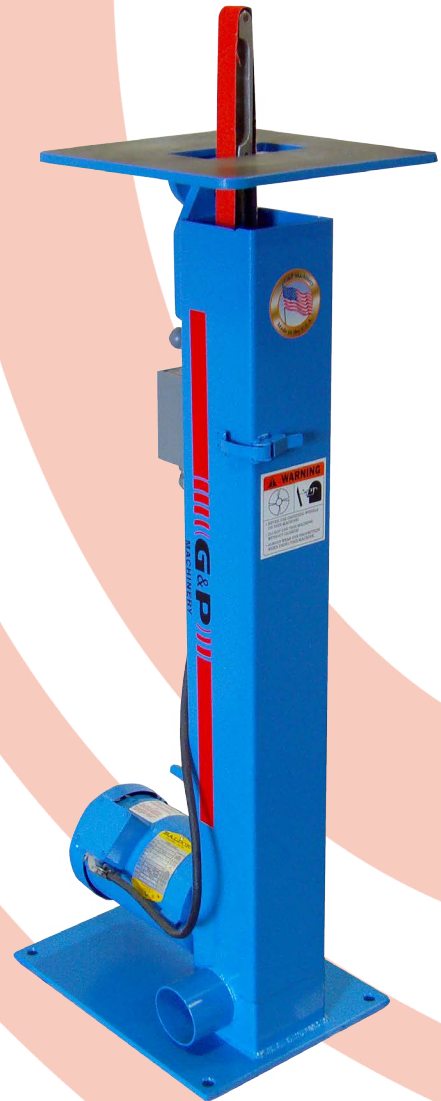

GRINDING & POLISHING MACHINERY CORPORATION
2801 TOBEY DRIVE / INDIANAPOLIS, IND. 46219
PHONE (317) 898-0750 FAX (317) 899-1627

G&P
MACHINERY

MULTI-PURPOSE ABRASIVE BELT GRINDER – for hard to reach areas

BULLETIN TS-90D
REV. Dec. 2014

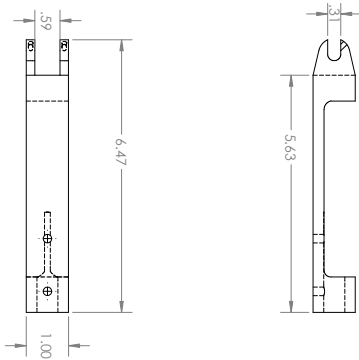

TYPE 1. (M-10058-B) Standard Top Bearing Assembly for general purpose use. Features platen one side and slack of belt on opposite side. Can be used on internal applications of 1" x 1-1/4" opening. Accommodates abrasive belts 1" x 90".

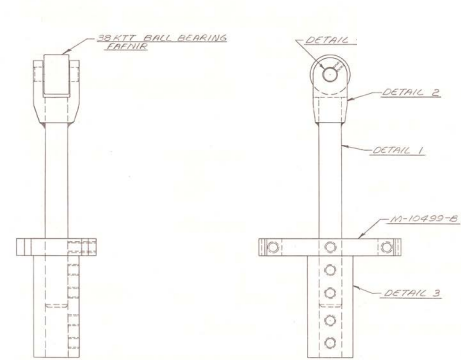

TYPE 2. (M-10503-C) Top Bearing Assembly with Spreader Bar. Equipped with replaceable carbide tips at points of greatest wear. Features slack of belt for developing convex radii on internal surfaces – either straight or curved shapes. Will fit minimum opening 1-1/8" x 1-1/4". Accommodates abrasive belts 1" x 90". Spreader bar can also be used with type 1 by installing below the assembly.

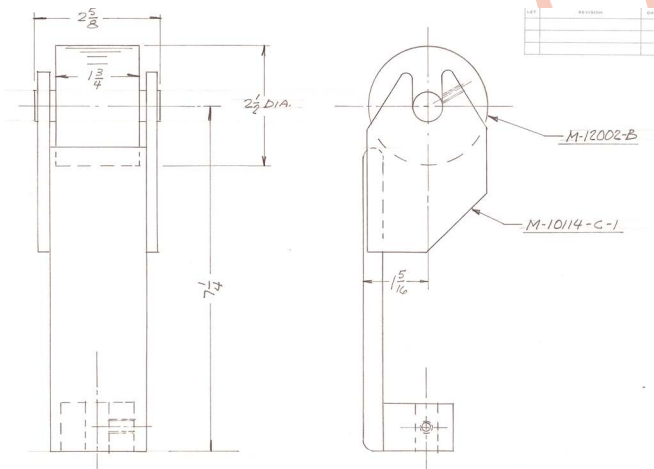

TYPE 4. (M10504-C-1) Top Bearing Assembly. General purpose work where heavier grinding is needed. Features heavier construction, increased width and rubber covered contact wheel. Permits working on wheel, platen or slack of belt. Will fit internal opening 2-3/4" square. Accommodates abrasive belts 2" x 90".

G&P Model TS 90D

The basic unit has a 1 horsepower 3450 RPM totally enclosed motor and switch for use with 115 volt 1 phase 60 hz electrical power. There are three top bearing assemblies available as described in the drawing on this page. A 90" long belt is used with all three. Types 1 and 2 require 1" width and type 4 requires 2" width. The belt is spring tensioned.

An adjustable tilting table is an accessory that is frequently ordered with this grinder.

Always wear eye protection when operating this or any other grinding equipment.