

# G&P MODEL SBS BACKSTAND IDLER INSTRUCTION SHEET

**NOTE: BOLTS "T" MUST BE LOOSENED TO ADJUST TENSION**

**1. INSTALLATION: RIGHT -- HAND MOUNTING**

With proper length belt, place belt over idler and move backstand base until arm of idler is at approximately 11 o'clock as shown. Mark the front and back edges of base on the mounting surface.

2. Align contact and idler pulleys with straight edge. Install bolts at center of slots in base, for additional adjustment.

3. With base bolted to the mounting surface, and belt removed, loosen bolts "T". Move idler arm to an "at rest" position of 1 to 3 o'clock. Belt width determines setting narrow width approximately 1 o'clock, with 3 o'clock for wider belts. Tighten bolts "T" securely to avoid slippage.

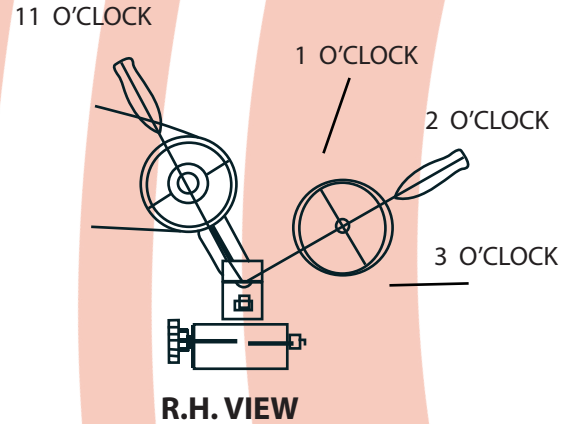

**IMPORTANT: BEFORE BACKSTAND IDLER CAN BE USED, BOLTS "X" MUST BE TIGHTENED SECURELY.**

**1. INSTALLATION: LEFT -- HAND MOUNTING**

Follow procedure as in right-hand instruction except locate base on mounting surface with arm at approximately 1 o'clock as in sketch of left-hand view.

2. Same as for right-hand.

3. Same as for right-hand except at rest position would be 9 to 11 o'clock, with narrow belt at 11 o'clock.

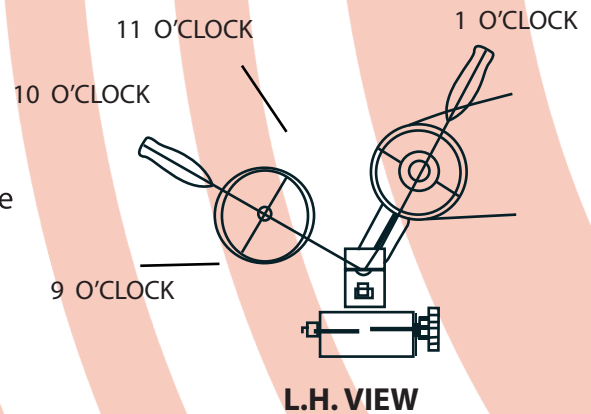

ON BOTH LEFT-HAND & RIGHT-HAND MOUNTINGS, TRACKING KNOB MAY BE REMOVED, AND TRACKING ADJUSTMENT EXTENDED TO THE MACHINE BY MEANS OF 3/8" ROD AND A UNIVERSAL JOINT

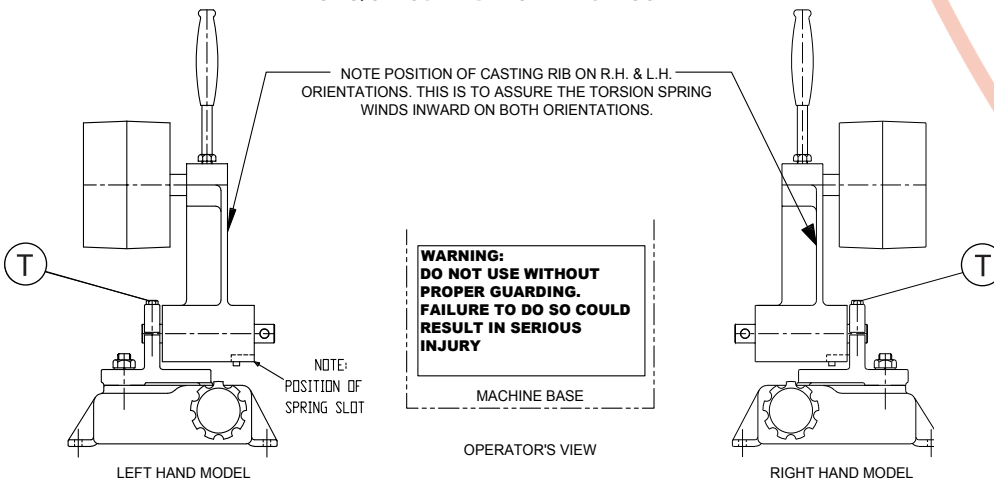

# PARTS LIST & INSTRUCTIONS FOR G&P SBS BACKSTAND IDLER

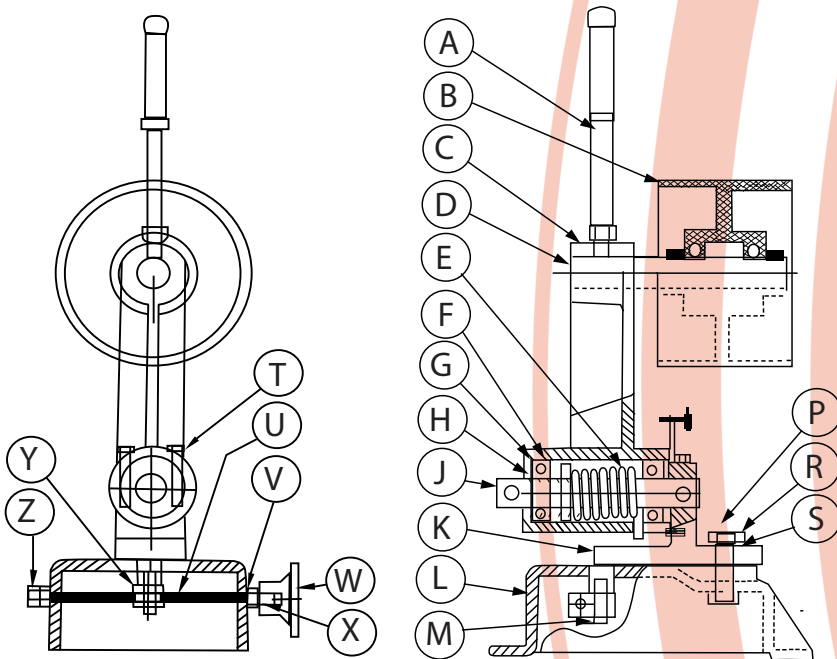

ITEM	PART NO.	DESCRIPTION	QTY.
A	M-10958-E4	Handle	1
B	M-9426-E	Idler Wheel 6" Dia	1
C	M-10958-E2	Arm	1
D	M-11026-C	Shaft	1
E	M-11418-B-1	Spring	1
F	1640-DC	Ball Bearing	2
G	N-5000-200	Snap Ring	3
H	5100-87	Snap Ring	2
J	M-11416-C	Shaft-Arm Pivot	1
K	M-10958-E1	Lever - Tracking	1
L	M-10959-E	Base	1
M	H.H.C.S.	5/16 -18 x 1 1/4 Lg.	1
P	H.H.C.S.	5/8 -11 x 2 1/4 Lg.	1
R	Hexnut	5/8 -11	1
S	Lockwasher	5/8 I.D.	1
T	H.H.C.S.	5/16 -18 x 1 5/8 Lg.	2
U	All Thd.	3/8 -16 x 7 3/4 Lg.	1
V	Spring Washer	3/8 I.D.	1
W	733-B	Tracking Knob	1
X	Nut	3/8 -16 Hex. Jam	1
Y	M-11417-B	Tracking Yoke	1
Z	Nut	3/8 -16 Hex. Jam	2

## G&P MODEL SBS BACKSTAND

### TO CHANGE FROM RIGHT-HAND TO LEFT-HAND

- 1 - Loosen Lever "A" and remove pulley-shaft assembly "B" and "D" and replace on other side of arm "C".
- 2 - Loosen bolts "T", remove arm and shaft assembly, and install opposite end of shaft "J" on same side of lever "K"
- 3 - Interchange outside nut "Z" and knob "W".

### TO TENSION SPRING

- 1 - Slip belt over idler pulley.
- 2 - Loosen bolts "T".
- 3 - Pull handle to tension belt.
- 4 - Rotate shaft "J" about 1/3 to 1/2 turn.
- 5 - Tighten bolts "T".



**GRINDING & POLISHING MACHINERY CORPORATION**

2801 TOBEY DRIVE / INDIANAPOLIS, IND. 46219

PHONE (317) 898-0750 WWW.GANDPMACHINERYIN.COM