

BRUSHES & BRUSH HOLDERS

DIMENSIONAL DATA FOR BRUSHES & BRUSH HOLDERS

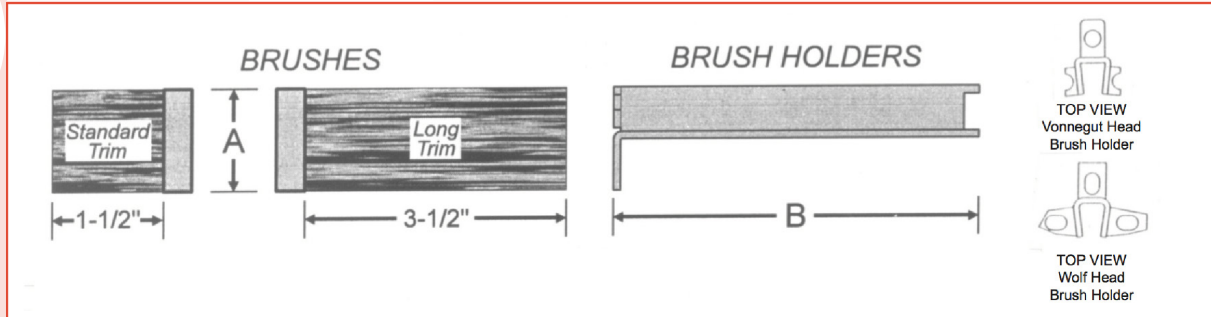

BRUSH & BRUSH HOLDERS FOR 16 AND 32 BRUSH WOLF HEADS

ABRASIVE WIDTH	MODEL NUMBER		BRUSH NUMBER		"A" DIMENSION	BRUSH HOLDER NUMBER		"B" DIMENSION
	32 BRUSH	16 BRUSH	STD. TRIM	LONG TRIM		ZINC	HARD CHROME	
1"	W-1001	WH-1041	SH-357	SH-358	1-3/8"	P-1001		1-7/8"
2"	W-1002	WH-1042	SH-215	SH-306	2-7/8"	P-1002		3-7/8"
4"	W-1004	WH-1044	SH-065	SH-304	4-7/8"	P-1004		5-5/8"
6"	W-1006	WH-1046	SH-091	SH-309	6-7/8"	P-1006		7-7/8"

BRUSH & BRUSH HOLDERS FOR 12 BRUSH PORTABLE HEAD

ABRASIVE WIDTH	MODEL NUMBER	BRUSH NUMBER		"A" DIMENSION	BRUSH HOLDER NUMBER		"B" DIMENSION
		STD. TRIM	LONG TRIM		ZINC	HARD CHROME	
1"	SH-1061	SH-357	SH-358	1-3/8"	SH-360	N/A	1-11/16"
1-1/2"	SH-1062	SH-329	SH-378	1-7/8"	SH-333	N/A	2-1/8"
2"	SH-1062	SH-215	SH-306	2-7/8"	SH-213	SH-222	3-1/8"

BRUSH & BRUSH HOLDERS FOR OBSOLETE VONNEGUT HEADS

ABRASIVE WIDTH	MODEL NUMBER		BRUSH NUMBER		"A" DIMENSION	BRUSH HOLDER NUMBER		"B" DIMENSION
	32 BRUSH	16 BRUSH	STD. TRIM	LONG TRIM		ZINC	HARD CHROME	
1"	SH-1031	SH-1041	SH-357	SH-358	1-3/8"	SH-360	N/A	1-11/16"
2"	SH-1030	SH-1042	SH-215	SH-306	2-7/8"	SH-213	SH-222	3-1/8"
4"	SH-1028	SH-1044	SH-065	SH-304	4-7/8"	SH-127	N/A	5-1/8"
6"	SH-1029	SH-1046	SH-091	SH-309	6-7/8"	SH-188	N/A	7-1/8"



GRINDING & POLISHING MACHINERY CORPORATION

2801 TOBEY DRIVE / INDIANAPOLIS, IN 46219

PHONE (317) 898-0750 • FAX (317) 899-1627